

(SINO-USA)
 DAFENG LIDA COMPRESSED AIR SYSTEMS CO., LTD

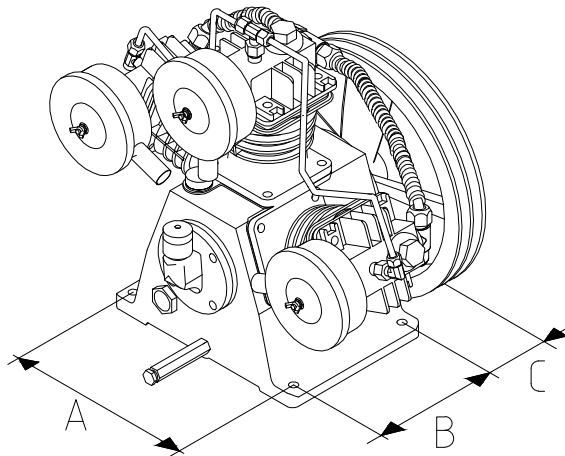

Dimensions		
A (Location)	inch	8.74
	mm	222
B (Location)	inch	5.91
	mm	150
C (Location)	inch	4.65
	mm	118
L (Shape)	inch	13.39
	mm	340
W (Shape)	inch	18.5
	mm	470
H (Shape)	inch	14.17
	mm	360
Weight	lb	62.28
	kg	28.25

GS13 Technical Data		
Motor	HP	2
	KW	1.5
Air Delivered	ACFM	6.145
	m ³ /min	0.174
Pressure	PSI	101.50
	Bar	7
Rpm	635	
Cylinders	3	
Bore	inch	2.559
	mm	65
Stroke	inch	1.89
	mm	48
Flywheel dia.	inch	10.63
	mm	270
Groove Type	A	

MODEL GS13 Single Stage Air Compressor Pump

(SINO-USA)
DAFENG LIDA COMPRESSED AIR SYSTEMS CO., LTD

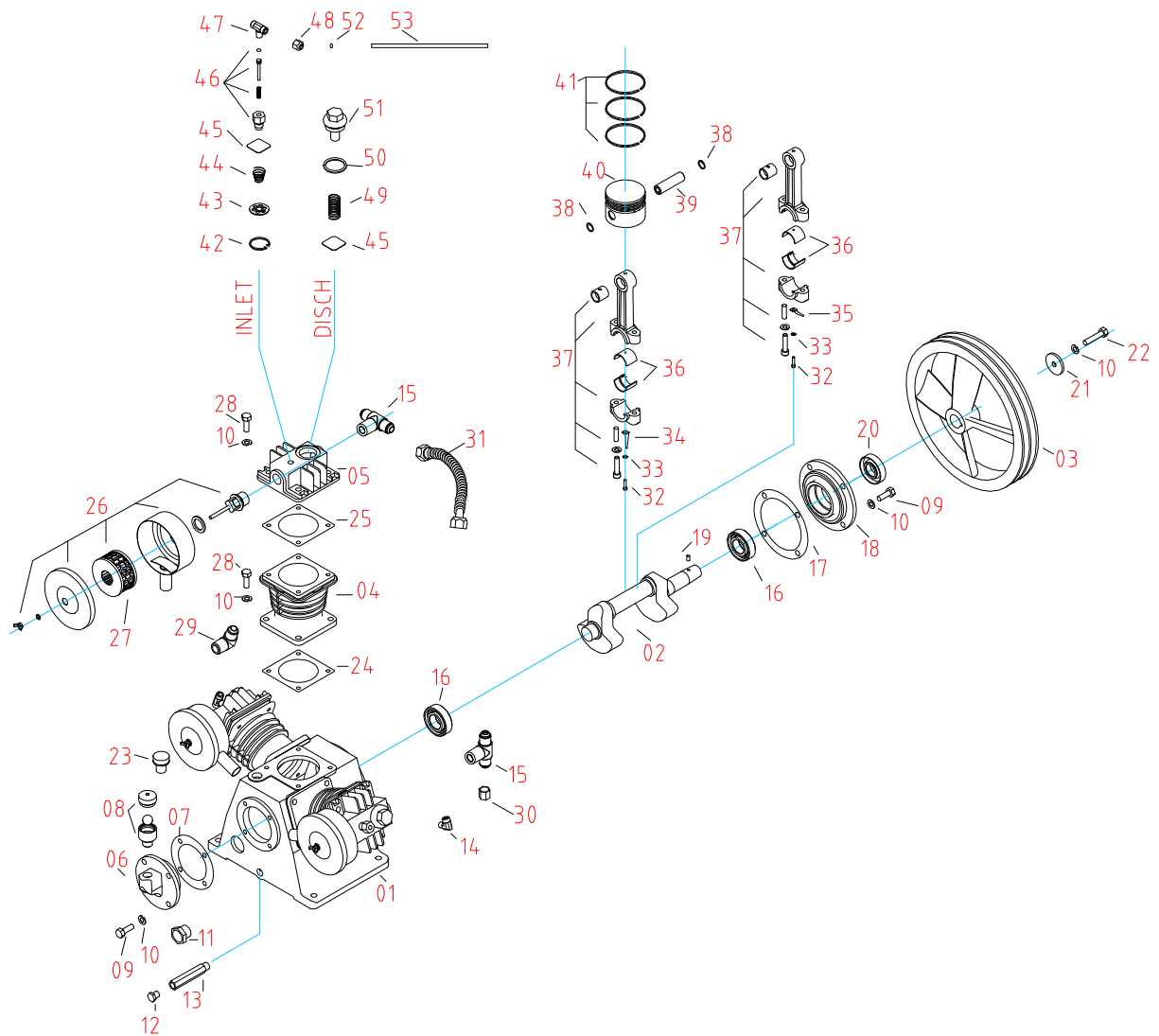

MODEL GS13 Single Stage Air Compressor Pump

(SINO-USA)

DAFENG LIDA COMPRESSED AIR SYSTEMS CO., LTD

GS13 PARTS			
ITEM	PARTS#	DESCRIPTION	QIY
1	131001	CRANKCASE GS13	1
2	131002	CRANKSHAFT GS13	1
3	131003	FLYWHEEL GS13	1
4	121004	CYLINDER GS12	3
5	121005	HEAD GS12	3
6	121006	CAP-REAR GS12	1
7	121101	CASKET-REAR CAP GS12	1(*a)
8	121102	BREATHER-CRANKCASE GS12	1
9	121103	CAPSCREW-HEX M8X20	8
10	121104	LOCKWASHER Φ 8	33
11	121105	OIL SIGHT GLASS GS12	1
12	121106	OIL DRAIN PIPE CAP GS12	1
13	121107	OIL DRAIN PIPE GS12	1
14	121108	COPPER ELBOW GS12	1
15	131109	TEE GS13	2
16	121110	BEARING GS12	2
17	121111	CASKET-FRONT CAP GS12	1(*a)
18	121112	CAP-FRONT GS12	1
19	121113	CYLINDER KEY GS12	1
20	121114	SEAL-SHAFT GS12	1
21	121115	SPACER-FLYWHEEL GS12	1
22	121116	CAPSCREW-HEX M8X35	1
23	121117	OIL PLUG GS12	1
24	121118	GASKET-CYLINDER TO CRANKCASE GS12	3(*a)
25	121119	GASKET-CYLINDER HEAD GS12	3(*a)
26	121120	FILTER-INLET ASSEMBLY GS12	3
27	121121	FILTER-REPLACEMENT ELEMENT GS12	3
28	121122	CAPSCREW-HEX M8X25	24
29	121123	ELBOW GS12	1
30	121124	NUT-COMPRESSION GS12	4
31	131125	INTERCOOLER TUBE GS13	2
32	121126	SCREW M5X10	3
33	121127	LOCKWASHER Φ 5	3
34	131128	STRAIGHT DIPPER-OIL GS13	1
35	131129	OBLIQUE DIPPER-OIL GS13	2
36	121130	INSERT HALF GS12	6
37	121131	CONNECTING ROD GS12	3
38	121132	SNAP RING-INTERNAL ϕ 16	6

MODEL GS13 Single Stage Air Compressor Pump

(SINO-USA)

DAFENG LIDA COMPRESSED AIR SYSTEMS CO., LTD

GS13 PARTS			
ITEM	PARTS#	DESCRIPTION	QTY
39	121133	WRIST PIN-PISTON GS12	3
40	121134	PISTON GS12	3
41	121135	PISTON RING SET GS12	3
42	121136	SNAP RING-INTERNAL \varnothing 32	3
43	121137	VALVE GUIDE GS12	3
44	121138	INLET SPRING GS12	3
45	121139	VALVE PLATE GS12	6
46	121140	UNLOADER ASSEMBLY GS12	3
47	121141	TEE-MALE TUBE GS12	2
48	121142	COPPER NUT GS12	4
49	121143	DISCH SPRING GS12	3
50	121144	GASKET-HOLD DOWN COVER GS12	3(*a)
51	121145	HOLD DOWN COVER GS12	3
52	121146	COPPER SEAL RING GS12	4
53	121147	ALUMINUM TUBE \varnothing 6 GS12	2
*a	130000	GASKET SET GS13	1

MODEL GS13 Single Stage Air Compressor Pump