

# Rotary Screw Compressors Gas & Diesel Driven

## Owners Manual



**Introduction.** Congratulations on the purchase of your new air compressor. The air compressor is precision built from the finest materials using the finest state of the art design, and high tech engineering available today. Quality, performance and trouble free operation will assure you a dependable supply of air power on demand.

Check [www.compressed-air-systems.com](http://www.compressed-air-systems.com) for most up to date manual and compressor service and technical information

**CAUTION** READ THIS MANUAL CAREFULLY before operating or servicing this air compressor, to familiarize yourself with the proper safety, operation, and standard operating procedures of this unit. **FAILURE TO COMPLY WITH INSTRUCTIONS IN THIS MANUAL COULD RESULT IN THE VOIDING OF YOUR WARRANTY, AND PERSONAL INJURY, AND/OR PROPERTY DAMAGE. THE MANUFACTURER OF THIS AIR COMPRESSOR WILL NOT BE LIABLE FOR ANY DAMAGE BECAUSE OF FAILURE TO FOLLOW THE INSTRUCTIONS IN THIS MANUAL.** By following the instructions and recommendations in this manual you will ensure a longer and safer service life of your air compressor.

If you have questions or need clarification about this manual or your compressor call 800-531-9656

***Do not operate compressor outdoors in wet weather***

**Compressed Air Systems**

Simplicity. It's What We Do.

[compressed-air-systems.com](http://compressed-air-systems.com) | 1-800-531-9656 | Fax 972-352-6364



**WARNING:** Read all installation steps in install guide, and compressor package manual prior to un-crating or installing compressor package. Failure to do so can result in personal injury or damage to compressor package.

**NOTICE:** All compressor air receivers should be inspected by a certified pressure vessel technician at least once per year, to check for leaks, weak points in the metal or any other deformity of the air receiver. If at any time a receiver appears out of conformance with ASME/CRN certification or a deformity is believed to have developed no matter how minor it may appear the tank should be locked out of service immediately and replaced with a certified ASME/CRN certified air receiver immediately before the compressor can be put back into service. The receivers should have a general inspection weekly as part of normal service.

### SAFETY PRECAUTIONS AND WARNINGS

Listed are some, but not all safety precautions that must be observed with compressors and compressed air systems. Failure to follow any of these warnings may result in severe personal injury, death, property damage and/or compressor damage.

Air from this compressor will cause severe injury or death if used for breathing or food processing.

Air used for these processes must meet OSHA 29 CFR 1910 or FDA 21 178.3570 regulations.

This compressor is designed for use in the compression of normal atmospheric air only. No other gases, vapors or fumes should be exposed to the compressor intake, nor processed through the compressor.

Disconnect all power supplies to the compressor plus any remote controllers prior to servicing the unit.

Relieve all pressure internal to the compressor prior to servicing.

Do not depend on check valves to hold system pressure.

A properly sized safety valve must be installed in the discharge piping ahead (upstream) of any shut-off valve (block valve), heat exchanger, orifice or any potential blockage point. Failure to install a safety relief valve could result in rupturing or explosion of some compressor or safety component.

Do not change the pressure setting of the safety relief valve, restrict the function of the safety relief valve, or replace the safety valve with a plug.

Over pressurization of some system or compressor component can occur, resulting in severe personal injury, death and property damage.

Never use plastic pipe, rubber hose, or soldered joints in any part of the compressed air system.

Failure to ensure system compatibility with compressor piping is dangerously unsound.

Never use a flammable or toxic solvent for cleaning the air filter or any parts.

Do not attempt to service any part while the compressor is operating.

Do not operate the compressor at pressures in excess of its rating.

Do not remove any guards while the compressor is operating.

Observe gauges daily to ensure compressor is operating properly.

Follow all maintenance procedures and check all safety devices on schedule.

Compressed air is dangerous, do not play with it.

Use the correct lubricant at all times.

Always wear proper safety equipment when using compressed air.

Always install compressor to all local applicable electric codes.

**WARNING:** Always wear proper protective eye ware, hearing protection and safety clothing when working around the compressor package. No loose or baggy clothing should be worn around compressor package at any time.

**WARNING:** On Electric motor powered air compressors make sure electrical system is up to National Electric Code (NEC) prior to installing compressor system. Failure to install a compressor with a proper NEC electrical system can cause personal injury, compressor package damage and void compressor package warranty

**NOTICE:** To ensure full compressor tank warranty all tank mounted compressor packages must be mounted on factory approved vibration isolation pads. A compressor should NEVER be installed while still on or in its original packaging. Failure to properly install the compressor system with approved vibration isolation pads will result in the compressor tank warranty being void.

**WARNING:** Compressed Air Systems compressors can operate at pressures from 0-250psi depending on the compressor package design and build specifications. Always verify that the system the compressor is installed into can handle the maximum operational pressure the compressor. NEVER install a compressor in a system that can not handle the compressors maximum operating pressure.

**WARNING:** Compressed air is extremely dangerous when not properly used or installed. Always make sure a trained compressed air professional has looked over the air system prior to use. Improper installation or use of compressed air can cause bodily injury or death. NEVER pressurize an object that was not designed to be pressurized. Pressurizing objects not properly engineered for the maximum operating pressure of the compressor system can cause bodily injury or death.

**WARNING:** Never apply air pressure to compressor crank case, always make sure crank case vent is clear and free from obstructions. Adding pressure to the crank case can cause serious bodily injury or death.

**WARNING:** Never operate a compressor in a moving vehicle or towable object in motion. Doing so can damage the compressor, compressor drive components, or auxiliary parts on the compressor package. Operating the compressor in a moving vehicle or towable object can cause serious bodily injury or death.

**WARNING:** Check function of safety valves, weekly to insure proper function, replace immediately if faulty or damaged.

**WARNING:** (Compressors Packaged with NEMA 7 Components)

Compressed Air Systems, LLC certifies that the electric motor, electrical enclosure and electrical conduit are rated for NEMA7/hazardous locations. (Only for applicable packages with NEMA7 added components)

Air compressors have multiple moving parts and potential points of contact that could create an ignition source. The compressor pumps are manufactured with ferrous metals and in some cases multiple moving parts can come in contact with one another causing an ignition source. Compressed Air Systems LLC does not guarantee this will not occur. Lack of maintenance or care can result in conditions that could also cause ignition sources.

Compressed Air Systems, LLC only guarantees that the electric motor, electrical enclosure and electrical conduit are rated for NEMA7 hazardous location. Compressed Air Systems LLC accept no other responsibility for the rating of the package.

## Troubleshooting Chart

NOTE: TROUBLESHOOTING PROBLEMS MAY HAVE SIMILAR CAUSES AND SOLUTIONS

**You should always contact an authorized service center before attempting to fix or repair your air compressor**

**Make sure drive engine battery is disconnected before any maintenance or repair**

**ALWAYS MAKE SURE COMPRESSOR DRIVE ENGINE KEY SWITCH IS OFF AND REMOVED FROM THE COMPRESSOR**

| Problem   | Possible causes   | Solutions   |
|---|---|---|
| Compressor Stalls and Dies                        | Drive engine low on fuel<br>Compressor check valve not functioning<br>Compressor Pilot valve not functioning<br>Spark Plug in Engine bad<br>Drive engine Low on oil | Check fuel level in drive engine<br>Inspect compressor check valve<br>Check drive engine spark plug<br>Check oil level on compressor drive engine<br>Check oil on compressor pump |
| Compressor is running and is not compressing air  | Compressor Pilot valve is actuated<br>Compressor pilot valve is malfunctioning<br>Compressors pump head unloaders stuck engaged                                     | Check pilot valve to make sure it in the proper position<br>Replace compressor pilot valve<br>Check and clean compressor pump head unloaders                                      |
| Compressor does not idle up for Compression       | Throttle control valve (bullwhip) not engaging<br>Throttle control valve cable broken<br>Drive engine throttle linkage damaged                                      | Check throttle control valve (bullwhip) for proper function<br>Replace throttle control valve<br>Check drive engine throttle linkage  |
| Compressor Airend bogs down while compressing air | Loose motor pulley or Compressor belts loose<br>Compressor pulley worn  | Check belts for wear<br>Check pulley for wear   |

## Troubleshooting Chart (continued)

NOTE: TROUBLESHOOTING PROBLEMS MAY HAVE SIMILAR CAUSES AND SOLUTIONS

**You should always contact an authorized service center before attempting to fix or repair your air compressor**

**Make sure drive engine battery is disconnected before any maintenance or repair**

**ALWAYS MAKE SURE COMPRESSOR DRIVE ENGINE KEY SWITCH IS OFF AND REMOVED FROM THE COMPRESSOR**

| Problem   | Possible causes   | Solutions   |
|---|---|---|
| Excessive oil discharge in air (All Compressors have a small amount of oil carry over in compression) | Worn piston rings or cylinder<br>Restricted air intake<br>Oil level too high<br>Compressor has exceeded its duty cycle  | Clean or replace air filters<br>Reduce oil level to recommended amount<br>Reduce compressor duty cycle (repair leaks or add another unit to handle the excess demand)   |
| Compressor Overheating  | Poor ventilation<br>Dirty cooling surfaces<br>Compressor is out of its operating duty cycle   | Relocate compressor to any area with better ventilation (at least 18 inches from the nearest wall)<br>Clean all cooling surfaces<br>Reduce compressor duty cycle (repair leaks or add another unit to handle the excess demand) |
| Excessive Belt Wear   | Pulley out of alignment<br>Improper belt tension<br>Pulley damaged or loose   | Realign pulley with flywheel<br>Re-adjust belt tension  |
| Compressor won't start in Cold weather  | Bad check valve<br>Compressor has wrong grade oil<br>Control lines frozen   | Use IS 100 (30W) compressor oil for cold weather conditions<br>Move compressor to a warmer location<br>Put a heat lamp on compressor to maintain above freezing temperatures  |
| Compressor Has Excessive vibration  | Compressor is not properly mounted on vibration isolation pads<br>Compressor pulley is out of alignment<br>Engine is low on fuel or throttle is out of adjustment | Properly mount compressor on vibration isolation pads<br>Re-align pulleys<br>Check drive engine oil and fuel level<br>Re-adjust engine throttle control (bull whip)   |

## **Normal Operation**

### **Start-Up**

Drain off condensate from the sump and check the oil level. Refill as necessary.

Check for any oil leaks. Correct as necessary.

On water cooled units, turn on the water.

Press the start button.

### **Stopping**

1. Make sure the compressor is fully unloaded before step 2. Unload the compressor by closing the service valve (this is a ball or block valve) placed in the system during compressor installation between the compressor and operating airlines for service and maintenance reasons.
2. After the unit has exhausted its contained pressure (this takes about 30 seconds) push the stop button.

### **Emergency Stopping**

Push the stop button.

Pull the main disconnect, if possible.

### **Air Filter**

The air filter is the primary protection of the compressor from harmful dirt being ingested into the oil system. It needs to be looked at periodically for clogging or holes. The period for these inspections is dependent on the environment the machine is in. For optimum life it is recommended that an air filter restriction indicator be used. Service simply based on hours is not recommended.

### **Element Inspection and Replacement**

Switch off the unit and disconnect the power to prevent accidental starting.

Allow one minute after stopping for the system to settle and the pressure to be relieved.

Loosen the nut that secures the cover and remove the cover.

Remove the element.

Place a bright light inside the element to inspect for damage or leak holes.

Inspect all gaskets and gasket contact surfaces of the housing. Correct any faulty conditions immediately.

Clean the housing with a damp cloth. Do not attempt to blow out dirt with compressed air.

Place a new element in the housing.

Replace the cover and tighten the nut.

Reset the filter indicator and the machine will be ready for operation.

If the compressor is turned off before being fully unloaded it can cause the unit to discharge oil into the air filter housing causing it to stop up or become contaminated.

### **Oil Filter**

The oil filter in the compressor system is a full flow replaceable canister type. Initially the filter should be replaced after 50 hours of operation. Then every 1000 hours or sooner as indicated by a maintenance gauge. This element protects the compressor bearings from grit and dirt ingress throughout the system. A dirty filter will cause an oil flow restriction that can result in high oil temperature and a unit shutdown.

## Compressor Maintenance

**WARNING:** To avoid personal injury, always shut OFF the main power supply and disconnects to the compressor, relieve all air pressure from the system, and check electrical system with electrical probe before starting any service or maintenance on the compressor.

### Daily:

Drain the Receiver- condensation will accumulate in the tank daily, and should be drained at least once a day. This is done to reduce corrosions of the tank from the inside. Always wear protective eyewear when draining the tank.

Check Pump Oil Level- All units have a sight glass the oil level non running units should be no lower than ½ way on the sight glass if it is lower then you need to add oil until it is at least ½ way up the sight glass.

Check unit for any unusual noise or vibrations

### Weekly:

Clean air filter: this will ensure that no dirt or heavy particulate makes its way into the compressors valve assemblies

Clean external parts of compressor and electric motor: this helps to ensure proper cooling and prevents rust and corrosion on critical parts

Check safety Valves: this is don't to ensure they are not stuck in place and operating properly

### Monthly:

Inspect complete air system for leaks: this is done to make sure the compressor does not get out of its duty cycle due to air leak in the system

Inspect Oil for Contamination: this is done to ensure that harmful deposits do not build up in the oil

Check belt tension: this is done to ensure the belt do not fail pre-maturely, tighten them as needed to ensure they do not slip

### Every 3 months:

Change Oil: this is done to ensure that the compressor has proper oil level and that the oil in the machine does not deteriorate past factory specifications

Inspect Valve assemblies: this is done to prevent premature failure and clean out and carbon that can form in older valves

### Storage of Compressor:

Before storing the compressor for a prolonged period of time, use a blow gun to clean all debris from compressor. Shut OFF main power and turn OFF disconnect. Drain tank pressure, clean air filter, drain old oil and replace with new oil. Cover the unit to prevent dust and moisture from collecting on the unit.

### Oil Analysis

Oil analysis is an excellent tool to add to your compressor maintenance program. At regular intervals you submit lubricant samples to a qualified laboratory. From this you receive a detailed report showing the lubricant condition, wear metals, and contaminants. Changes in this information over time provides the basis for predictive compressor maintenance. Saving you unplanned machine downtime and unnecessary oil changes.

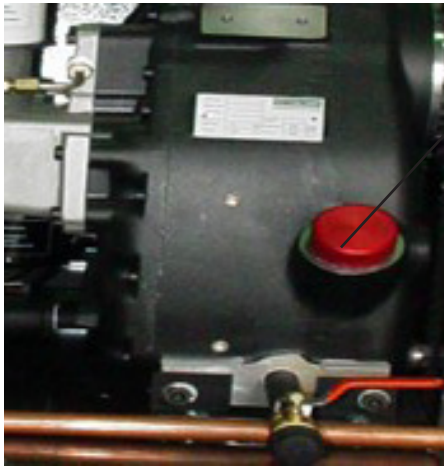

Oil Cap

Oil Drain Line

### Checking Oil Level and Adding Compressor Oil

1. Switch off the unit and disconnect the power to prevent accidental restarting.
2. Allow one minute after stopping the compressor for settling and the pressure to relieve.
3. Remove any dirt from around the fill cap, then remove the fill cap.
4. Inspect the o-ring in the cap for damage and cleanliness. Replace if necessary.
5. The oil should be between the bottom of the neck and the o-ring groove.
6. Replace the cap securely. Never put the cap on without tightening immediately.

### Changing Compressor Lubricant

Regular maintenance of the oil filter and the air filter will help prolong the life of the lubricant.

1. Switch off the unit and disconnect the power to prevent accidental restarting.
2. Allow one minute after stopping the compressor for settling and the pressure to relieve.
3. Remove any dirt from around the fill cap, and then remove the fill cap. If the lubricant appears dirty or has a foul smell, it should be replaced.
4. Drain the lubricant from the bottom of the air/oil receiver. Oil will drain more quickly and completely if is warm from operation.
5. Close all drains and replace with fresh CAS RS8000 to the proper level.
6. Replace the fill cap and run the unit.
7. Switch off the unit and disconnect the power to prevent accidental restarting.
8. Allow one minute after stopping the compressor for settling and the pressure to relieve.
9. Remove the fill cap to see if more lubricant should be added and to insure that there are no leaks.





**Hot oil under pressure will cause severe injury, death, or property damage.**

**Be sure the compressor is shutdown and pressure relieved before attempting to remove the oil filter, separator, oil fill, or change the oil.**

**Oil Filter Replacement**

1. Switch off the unit and disconnect the power to prevent accidental starting.
2. Allow one minute after stopping for the system to settle and the pressure to be relieved.
3. Using a strap wrench, remove the old element and gasket.
4. Clean the gasket surface with a clean rag.
5. Apply a light film of oil to the new gasket.
6. Hand tighten the new element until the new gasket is seated in the gasket groove.
7. Continue tightening by hand an additional ½ to ¾ turn.
8. Reconnect power and restart the machine to check for leaks.

**Air/Oil Separator**

The air/oil separator should be changed every 2000 hours, or when there is excessive oil vapor in the discharge air.

**Separator Element Replacement**

1. Switch off the unit and disconnect the power to prevent accidental starting.
2. Allow one minute after stopping for the system to settle and the pressure to be relieved.
3. Using a strap wrench, remove the old element and gasket.
4. Clean the gasket surface with a clean rag.
5. Apply a light film of oil to the new gasket.
6. Hand tighten the new element until the new gasket is seated in the gasket groove.
7. Continue tightening by hand and additional ½ to ¾ turn.
8. Reconnect power and restart the machine to check for leaks

**Lubricant**

Your compressor has been filled and tested with CAS RS8000, a high quality compressor lubricant. It is a PAO with the advantage of extended service life, high temperature operation, easy start-up when cold, reduced sludge and lacquer buildup, and is completely compatible with all seals, gaskets, and other compressor materials.

**Lubricant Specifications**

If you choose not to use CAS RS8000, for optimum life and warranty service your lubricant must meet the following specification:

|                            |             |
|----------------------------|-------------|
| Grade ISO                  | 46          |
| Viscosity@100oF,cST        | 46          |
| Viscosity@210oF,cST        | 7.93        |
| Viscosity Index            | 100 or more |
| Pour Point, F              | -20 or less |
| Flash Point, F             | 400 or more |
| Fire Point, F              | 450 or more |
| Rust Test ASTM-FG-665 A&B  | Pass        |
| Oxidation Test, ASTM0-D943 | 1500        |
| Emulsion Test, ASTM-D1401  | 10 Min.     |
| Foam Test, ASTM            | Pass        |

## **Descriptions**

### **Compressor**

The compressor assembly is a positive displacement, oil flood lubricated, helical rotary screw type unit employing a single stage of compression. The components include housing or stator, two rotors or screws, bearings and bearing supports.

In operation two helical grooved rotors mesh to compress air. Inlet air entering the compressor becomes trapped between the lobes of the rotors. As the rotors turn, this trapped volume of air is reduced in volume or compressed and is pushed to the discharge end of the compressor. This process delivers smooth flowing air at full pressure to the receiver.

During the compression cycle, oil is injected into the compressor for the purposes of lubricating, cooling, and sealing. Compressed air laden with oil leaves the compressor through a discharge port designed to provide optimum performance within the desired pressure range.

### **Air/Oil System**

The air/oil system is almost completely contained within the compressor housing. Within or directly attached to the housing are the air filter, oil filter and the air/oil separator element.

### **Air Filter**

The air filter is a high efficiency ring style located on top of the inlet valve of the compressor. It will provide nearly constant efficiency of filtration at all load conditions. The element has a high dirt holding capacity for a long life. It is specially treated to be insensitive to heat, cold, water, and oil.

### **Oil Filter**

The oil filter is a 10-micron spin-on style. It is sized to maintain system cleanliness and to give good service life. The housing is equipped with a bypass to insure that there is oil flow on startup. The restriction created at the filter will have a direct effect on the operating temperature of the compressor. So you must be sure to maintain it.

### **Air/Oil Separator**

This unit utilizes a spin-on air/oil separator to make maintenance much more convenient than the element in vessel design. This does not diminish its operating efficiency. In fact the separation of the element from the pre-separation tank enhances the performance. The purpose of the separator is to remove aerosols. The vapor pressure of the oil, the operating temperature of the unit, operating pressure of the unit and the operating cycle will affect its performance.

### **Minimum Pressure Valve**

As the compressed air leaves the compressor it goes through a minimum pressure valve. This is set to maintain at least 85 psig (586kPa) in the sump when the compressor is running. This is to insure that there is pressure to force the oil out of the sump and through the oil system so that sufficient oil is injected into the compressor. It is also necessary to provide good air/oil separation. The valve acts as a check valve to prevent back flow into the compressor from the plant system.

### **Cooling**

The compressor has an air-cooled and after-cooler as standard. The following are the heat loads and cooling airflow rates that must be accommodated.

**WARNING:** Always wear proper protective eye ware, hearing protection and safety clothing when working around the compressor package. No loose or baggy clothing should be worn around compressor package at any time.

**WARNING:** On Electric motor powered air compressors make sure electrical system is up to National Electric Code (NEC) prior to installing compressor system. Failure to install a compressor with a proper NEC electrical system can cause personal injury, compressor package damage and void compressor package warranty

**NOTICE:** To ensure full compressor tank warranty all tank mounted compressor packages must be mounted on factory approved vibration isolation pads. A compressor should NEVER be installed while still on or in its original packaging. Failure to properly install the compressor system with approved vibration isolation pads will result in the compressor tank warranty being void.

**WARNING:** Compressed Air Systems compressors can operate at pressures from 0-250psi depending on the compressor package design and build specifications. Always verify that the system the compressor is installed into can handle the maximum operational pressure the compressor. NEVER install a compressor in a system that can not handle the compressors maximum operating pressure.

**WARNING:** Compressed air is extremely dangerous when not properly used or installed. Always make sure a trained compressed air professional has looked over the air system prior to use. Improper installation or use of compressed air can cause bodily injury or death. NEVER pressurize an object that was not designed to be pressurized. Pressurizing objects not properly engineered for the maximum operating pressure of the compressor system can cause bodily injury or death.

## Compressor Maintenance

**Warning: To avoid personal injury, always turn drive engine key off and remove from compressor, relive all air pressure from the system, also disconnect the battery power connections before starting any service or maintenance on the compressor**

### Daily:

**Drain the Receiver-** condensation will accumulate in the tank daily, and should be drained at least once a day. This is done to reduce corrosions of the tank from the inside. Always wear protective eyewear when draining the tank.

**Check Pump Oil Level-** All units have a sight glass the oil level non running units should be no lower than ½ way on the sight glass if it is lower then you need to add oil until it is at least ½ way up the sight glass.

Check unit for any unusual noise or vibrations

### Weekly:

**Clean air filter:** this will ensure that no dirt or heavy particulate makes its way into the compressors valve assemblies

**Clean external parts of compressor and electric motor:** this helps to ensure proper cooling and prevents rust and corrosion on critical parts

**Check safety Valves:** this is don't to ensure they are not stuck in place and operating properly

### Monthly:

**Inspect complete air system for leaks:** this is done to make sure the compressor does not get out of its duty cycle due to air leak in the system

**Inspect Oil for Contamination:** this is done to ensure that harmful deposits do not build up in the oil

**Check belt tension:** this is done to ensure the belt do not fail pre-maturely, tighten them as needed to ensure they do not slip

### Every 3 months:

**Change Oil:** this is done to ensure that the compressor has proper oil level and that the oil in the machine does not deteriorate past factory specifications

**Inspect Valve assemblies:** this is done to prevent premature failure and clean out and carbon that can form in older valves

### Storage of Compressor:

Before storing the compressor for a prolonged period of time, use a blow gun to clean all debris from compressor. Shut OFF main power and turn OFF disconnect. Drain tank pressure, clean air filter, drain old oil and replace with new oil. Cover the unit to prevent dust and moisture from collecting on the unit.

## Troubleshooting Chart Generator

NOTE: TROUBLESHOOTING PROBLEMS MAY HAVE SIMILAR CAUSES AND SOLUTIONS

**You should always contact an authorized service center before attempting to fix or repair your air compressor.**

**Always make sure electrical power is off before removing any inspection covers or plates or before servicing compressor.**

**ALWAYS MAKE SURE COMPRESSOR DRIVE ENGINE KEY SWITCH IS OFF AND REMOVED FROM THE COMPRESSOR**

| Problem                   | Possible causes   | Solutions   |
|---------------------------|---|---|
| Voltage Low               | Engine Speed to low<br>Generator overloaded   | Replace or repair engine throttle device<br>Reduce load on generator by unplugging components                 |
| Circuit Breaker Trips     | Defective load connected to generator<br>Defective receptacle<br>Generator overloaded   | Disconnect load<br>Replace receptacle<br>Reduce load on generator   |
| Voltage Too High          | Drive engine speed to high  | Reduce drive engine speed   |
| Generator is over-heating | Generator is overloaded<br>Insufficient ventilation   | Reduce load on generator<br>Make sure adequate air flow to generator and engine                               |
| No voltage output         | Defective load connected<br>Broken or loose wire<br>Defective receptacle<br>Defective stator<br>Defective rotor<br>Defective capacitor<br>Circuit breaker tripped | Disconnect load<br>2-6 Have generator checked out by authorized generator technician<br>Reset circuit breaker |

## Adjusting Belt Tension

Proper belt tension and pulley alignment must be maintained for maximum drive efficiency and for maximum belt life. The correct tension exists if a deflection of 1/2 inch occurs by placing 10lbs of force midway between the motor pulley and the compressor flywheel. This deflection can be adjusted by the following procedure. The pulley should be carefully aligned with the flywheel and set screws should be kept tight.

1. Remove the belt guard
2. Loosen the motor mounting bolts
3. Shift the motor to the point where the correct deflection exists
4. Retighten the motor mounting belts
5. Check to ensure that the tension remain correct after tightening
6. Re-install the belt guard. All moving parts must be guarded

NOTE: Drive belt tension and pulley alignment are done at the same time. They are discussed separately for clarity.

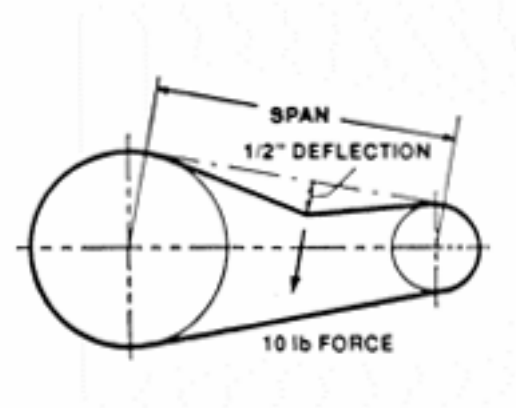

## Pulley Alignment

The figure to the side shows 3 examples of misaligned pulleys. To check pulley alignment, remove the belt guard and place a straightedge against the compressor flywheel, measure and record the distance from the straightedge to the edge of the drive belt. Then measure the distance to the edge of the drive belt on the motor pulley at the same edge. As long as both points measure the same distance the pulleys will be aligned if not you will need to move the pulley until its in alignment this may take a few tries. To re-align the pulley follow the steps below

1. Loosen the motor mounting bolts
2. Remove the belt guard
3. Loosen the set screw on the motor pulley
4. Align the motor pulley with the compressor flywheel
5. Re-tighten the motor pulley set screws
6. Adjust the proper belt tension
7. Re-tighten the motor mounting bolts
8. Re-install the belt guard

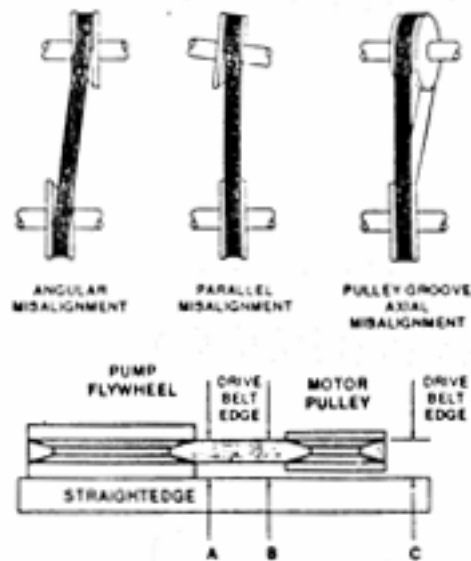

## Receiving and Uncrating of your Compressor

Before uncrating the compressor the following steps should be taken.

1. Immediately upon receipt of the equipment, it should be inspected for damage that may have occurred during shipment. If any damage is found, demand an inspection immediately by an inspector from the carrier. Ask him how to file a claim for damages. (See Appendix "A" for Details).
2. Insure that adequate lifting equipment is available for moving the machinery.
3. Read the compressor nameplate to be sure the compressor is the model and size ordered.
4. Read the motor nameplate to be sure the motor is compatible with your electrical conditions. (Volts-Phase-Hertz).

**IMPORTANT: Compressor drive engine comes with its own manual refer to drive engine manual for any specifications or troubleshooting issues with the drive engine of the air compressor**



**CAUTION**

Improper lifting can result in component or system damage or personal injury.

Follow good shop practices and safety procedures



**CAUTION**

Under no circumstances should a compressor be placed in an area that may be exposed to a flammable, toxic, volatile or corrosive atmosphere nor should flammable, toxic, volatile or corrosive agents be stored near the compressor.

## Compressor Installation

### LOCATION

Locate the compressor in an area that is clean, dry, well lighted, and well ventilated, with sufficient space for safe and proper inspection and maintenance. Ambient temperatures should not exceed 110 degrees F or fall below 30 degrees unless. Inspection and maintenance checks are required daily, therefore, ample space is required around the compressor.

The compressor must not be installed closer than 24 inches from a wall or other solid structure to allow ample circulation of air across the compressor cylinders and head, and through the coolers if they are part of the system. Additional safety can be achieved by locating the pulley guard next to the wall or solid structure.

### MOUNTING

The use of the factory supplied rubber vibration isolation pads, or other factory supplied vibration isolation mounting equipment is required for tank warranty from the original tank manufacturer. The compressor should never be left on original shipping material for installation. If a shim is required to level the unit, place it between the pad and floor. If you bolt the unit to the floor, use the bolts as guide pins and do not tighten the bolts. The rubber pads are used to absorb machine vibration and cannot work effectively if bolted tightly.

### INDUCTION SYSTEM

Do not locate the compressor where it could ingest or ignite toxic, explosive or corrosive vapors, ambient air temperatures exceeding 110 degrees F, water or extremely dirty air. Ingestion of any of the above noted atmospheres by the compressor could jeopardize the performance of the equipment and all personnel exposed to the total compressed air system.

Destructive pulsations can be induced by reciprocating compressors that will damage walls and break windows. Pulsation can be minimized by adding a pulsation dampener on the inlet side of the compressor.

**For compressor tank to have full manufacturer warranty. The tank must be installed properly on manufacturer supplied vibration pads per compressor manual. Failure to do so can void compressor tank warranty and cause tank cracks or failures.**



## Compressor Installation continued

### NOISE

Noise is a potential health hazard that must be considered. There are local and federal laws specifying maximum acceptable noise levels that must not be exceeded. Most of the noise from a reciprocating compressor originates from the air inlet point. Excessive noise can be greatly reduced by installing an intake noise silencer. Intake noise silencers are available from the compressor manufacturer.

### PIPING FITUP

Care must be taken to avoid assembling the piping in a strain with the compressor. It should line up without having to spring or twist into position. Adequate expansion loops or bends should be installed to prevent undue stresses at the compressor resulting from the changes between hot and cold conditions. Pipe support should be mounted independently of the compressor and anchored as necessary to limit vibration and prevent expansion strains.



**Safety valves are to protect system integrity in accordance with ASME Codes and ANSI B19.3 safety standards. Failure to use safety valves of the proper capacity and pressure will cause severe personal injury or death.**

**NOTE:** Standard motors are open drip proof with a maximum ambient temperature rating of 104 degrees F. They are not suitable for salt laden, corrosive, dirty, wet, or explosive environments.

**SAFETY VALVES:** Safety valves are pressure relief valves and should be sized and purchased with a pressure setting to protect the weakest link in the system. Never change the pressure setting, only the safety valve manufacturer is qualified to make a change. Safety valves are to be placed ahead of any potential blockage point which included but is not limited to, shutoff valves, heat exchangers, pulsation dampeners, and discharge silencers.

**Failure to properly size, set and install pressure relief valves can be fatal.**



ASME coded pressure vessels must not be modified, welded, repaired, reworded or subjected to operation conditions outside the nameplate ratings. Such actions will negate code status, affect insurance status and may cause severe personal injury, death, and property damage.

### **PRESSURE VESSELS**

Air receiver tanks and other pressure containing vessels such as, but not limited to, pulsation bottles, heat exchangers, moisture separators and traps, shall be in accordance with ASME Boiler and Pressure Vessel Code Section VIII and ANSI B19.3 Safety Standards.



Relieve compressor and system air pressure by opening the appropriate manual relief valve prior to servicing.  
Failure to relieve all system pressure may result in severe personal injury, death and property damage.

### **MANUAL RELIEF AND SHUTOFF VALVES**

Install a manual relief valve to vent the compressor to atmosphere. In those instances where the air receiver tank services a single compressor, the manual relief valve can be installed on the receiver. When a manual shut-off valve, and a safety relief valve installed upstream from the manual relief valve. These valves are to be designed and installed as to permit maintenance to be performed in a safe manner. Never substitute a check valve for a manual shut-off valve (block valve) if the purpose is to isolate the compressor from a system for servicing.



**CAUTION**

Guards must be fastened in place before starting the compressor and never removed before cutting off and locking out the main power supply.

### **GUARDS**

All mechanical action or motion is hazardous in varying degrees and needs to be guarded. Guarding shall be in compliance with OSHA Safety and Health Standards 29 CFR 1910.219 in OSHA manual 2206 and any state or local code.



**CAUTION**

Excessive speed of the compressor or driver can be lethal. Never operate the compressor beyond the manufacturer's recommendation.

Bursting of the flywheel may be the greatest threat because the normal guard may not contain all the pieces.

Crankshaft and connecting rod breakage is a possibility and compressor efficiency, valve life and bearing life will be abnormally reduced.

### **DRIVES**

It is important that the compressor and motor pulleys are aligned properly and the V belt is correctly tensioned. Improper pulley alignment and belt tension are causes for motor overloading, excessive vibration, and premature belt and/or bearing failure.

**Removal or painting over safety labels will result in uninformed conditions. This may result in personal injury or property damage. Warnings signs and labels shall be provided with enough light to read, conspicuously located and maintained for legibility. Do not remove any warning, caution, or instructional material attached!**

**Provisions should be made to have the instruction manual readily available to the operator and maintenance personnel. If for any reason any part of the manual becomes illegible or if the manual is lost, have it replaced immediately.**

**The instruction manual should be periodically read to refresh one's memory, it may prevent a serious or fatal accident.**

## Start Up Preparation & Procedures

The following check list shall be adhered to before putting the compressor into operation.

**FAILURE TO PERFORM THE CHECKS MAY RESULT IN SERIOUS INJURY OR DEATH, PROPERTY DAMAGE AND/OR MECHANICAL FAILURE. DISCONNECT AND LOCK OUT POWER SUPPLY.**

1. Remove all loose pieces and tools around the compressor installation.
2. Check oil level in crankcase, add as necessary.
3. Check all pressure connections for tightness and leaks.
4. Check to make sure all safety relief valves are in place and operational.
5. Check to be sure all guards are in place and securely mounted.
6. Check fuses, circuit breakers and thermal overloads for proper size.
7. Open all manual shut-off valves (block valves) at and beyond the compressor discharge.

The following procedures should be followed for start-up of a new installation, or after changes have been made to an existing installation, and/or after service repair work has been performed.

1. Instructions in addition to those contained within this manual, supplied by manufacturers of supporting equipment, must also be read and understood before start-up.
2. Check oil level in crankcase.
3. Drain moisture from air receiver and traps.
4. Start compressor and watch for excessive vibration or strange noises. If either is observed, stop the compressor immediately and correct.
5. Check air receiver or system pressure.
6. Manually activated safety relief valves by pulling ring or lever.
7. Check operation of controls.
8. After two days of operation check belt tension, air piping for leaks, and crankcase oil level.

## Stopping for Maintenance or Service



**Never assume the compressor is ready for maintenance or service because it is stopped.**

**The automatic stop-start control may start the compressor at any time!**

The following procedure should be followed to maximize safety when preparing for maintenance or service.

1. Turn compressor drive engine key switch off and remove key from compressor.
2. Close shut-off valve (block or ball valve) between compressor and main supply (air tank or air lines). This is the valve installed to isolate the air compressor for maintenance or service. The valve is placed in the system during installation for the purpose of servicing the compressor and to not allow (shop or working) air back into the compressor during service. \*See note for turning compressor off while under a load or compressing air.
3. Lock open manual vent valve and wait for the pressure in the area to be serviced (compressor, receiver, etc.) to be completely relieved before starting service. The Manual vent valve may be the drain valve in the receiver. NEVER remove a plug to relieve the pressure.
2. Disconnect battery connection to compressor drive engine
3. Lock open manual vent valve and wait for the pressure in the area to be serviced (compressor, receiver, etc.) to be completely relieved before starting service. The Manual vent valve may be the drain valve in the receiver. NEVER remove a plug to relieve the pressure.
4. Open all manual drain valves within the area to be serviced.
5. Wait for the unit to cool before starting service, (temperatures at 125 degrees F can burn the skin), some surface temperatures exceed 400 degrees F when the compressor is working).
6. Clean up all oils spills immediately to prevent slipping.

\* Note. If the compressor is turned off before being fully unloaded it can cause the unit to discharge oil into the air filter housing and could cause the air filter element to become contaminated. This may happen when using the emergency shut-off button and/or the on/off switch

## Maintenance Procedures Review

### SAFETY PROCEDURES

Adherence to safe working procedures are important to Service personnel at the time of servicing and to those who may, at a later date be around the compressor and the system it serves. Routine maintenance insures trouble free operation and protects your investment. All warranties are void if maintenance is neglected.

### DAILY

**CHECK THE OIL LEVEL.** Maintain the level at the center of the sight glass with 30w non-detergent.

**DRAIN THE TANK.** Turn off the power to the compressor and drain all the moisture from the bottom of the tank.

### WEEKLY

**CLEAN THE OIL.** If the oil appears contaminated by moisture or dirt, change immediately.

**CHECK THE V BELTS.** Turn off the compressor and inspect the belts for damage, excessive wear, and correct tension. Replace if necessary.

**TEST THE SAFETY VALVE.** Pull the ring on the safety valve. Air should escape and then reset. In the event the compressor ran over pressure, the safety valve would reduce the tank pressure to a safe level. Never run the unit without this safety valve or attempt to adjust it.

**GENERAL INSPECTION.** Check the overall operation of the unit. Tighten any loosen bolts, inspect for air leaks and inspect for any unusual noises or vibrations.

### EVERY 3 MONTHS OR 500 HRS OF OPERATION

**CHANGE THE OIL.** Refill with Compressed Air Systems RS 8000 oil.

**INSPECT COMPRESSOR VALVES AND VALVE PLATES.** The compressor valves are manufactured from high quality stainless steel for long life. Inspect and clean the valves and valve plates by brushing with a stiff bristle brush. Do not use a steel or wire brush as severe damage to the sealing surfaces may result. Clean safety solvent may also be used to loosen carbon deposits. NEVER use gasoline, thinners or other flammable solutions to clean valves or related parts. Check to be sure the valves are seated against the sealing surface around each port. If the valves are not sealing, compressor capacity will be severely reduced and excessive heat will be generated, resulting in carbon build-up.

COMPRESSED AIR SYSTEMS, LLC.

# WARRANTY

C E R T I F I C A T E   O F   L I M I T E D   W A R R A N T Y

## Rotary Screw Compressors

All component parts on this compressor installed by the manufacturer are warranted to be free of defects, workmanship and material for a period of one year. Transportation charges are the responsibility of the purchaser. This warranty extends to the original purchaser of the compressor only.

There are NO express warranties except other than those contained in this limited warranty statement

Covered in the one year period of the warranty are defective parts due to defects in the original part only.

The compressor warranty is void in the cases of abuse, lack of proper service, in correct application, in correct installation, and neglect

Standard compressor warranty covers defective parts and labor for the one year period.

Industrial Electric stationary compressors may be repaired on site as long as the compressor is not located further than 50 miles from the service center. The purchaser is responsible for any additional travel expense past 50 miles from the service center.

Gas/Diesel engine driven compressors must be repaired at the closest service center to the compressor. The purchaser is responsible for any travel expense if they do not wish to bring the compressor to the service center.

**ALL "SPECIALTY COMPRESSOR" WARRANTY SERVICE MUST BE PERFORMED AT THE CLOSEST SERVICE CENTER TO THE COMPRESSOR**

Specialty compressor-any compressor package with options other than those that apply to the standard model number in the catalog

The compressor "airend" is covered by a 2 year warranty to be free from defects from manufacturing. This does not cover abuse, neglect, improper service, misapplication, or improper installation. An oil sample must be submitted with any airend warranty claim for verification. The purchaser must use only Compressed Air Systems synthetic rotary screw oil in the compressor for the duration of the warranty.

### **Airend- the rotors and bearings of the compressor**

**BEFORE WARRANTY SERVICE IS PERFORMED CONTACT MANUFACTURER TECH SUPPORT FOR FASTEST SOLUTION**

Warranty labor for the first year is only covered for work performed Monday-Friday 8am-5pm excluding all major US holidays

**BEFORE WARRANTY SERVICE IS PERFORMED CONTACT MANUFACTURER TECH SUPPORT FOR FASTEST SOLUTION.**

## Rotary Screw Compressor Installation Sheet

Date of Installation \_\_\_\_\_ Compressor Model# \_\_\_\_\_

Installation Company \_\_\_\_\_ Compressor Serial # \_\_\_\_\_

Installation Technician \_\_\_\_\_ Compressor Voltage \_\_\_\_\_

Site Electrical Phase \_\_\_\_\_

Site Voltage \_\_\_\_\_

Compressor Electrical breaker size \_\_\_\_\_

Incoming Voltage at motor start up \_\_\_\_\_

Incoming Voltage at max operating pressure \_\_\_\_\_

Incoming power connected to Magnetic Starter \_\_\_\_\_

Compressor Rotation Correct \_\_\_\_\_

Motor amps at Max operating Pressure \_\_\_\_\_

Compressor Max Operating Pressure \_\_\_\_\_

Compressor tank drain functional \_\_\_\_\_

Unit inspected for Air leaks \_\_\_\_\_

Unit inspected for Oil leaks \_\_\_\_\_

Unit location:  Indoors  Outdoors (Put N/A if pressure not applicable to installed unit)

Unit tank fill time 0-125psi \_\_\_\_\_

Unit tank fill time 0-150psi \_\_\_\_\_

Unit tank fill time 0-175psi \_\_\_\_\_

Unit Cooling Fan (Pulls air through cooler) (Push's air through cooler)

Compressor Temperature switch reading (Before install) \_\_\_\_\_ (After install) \_\_\_\_\_

Unit unloads at max operating pressure and begins to release sump pressure \_\_\_\_\_ -

Belt tension checked \_\_\_\_\_

Vibration Pads properly installed \_\_\_\_\_







**WARNING:** Always wear proper protective eye ware, hearing protection and safety clothing when working around the compressor package. No loose or baggy clothing should be worn around compressor package at any time.

**WARNING:** On Electric motor powered air compressors make sure electrical system is up to National Electric Code (NEC) prior to installing compressor system. Failure to install a compressor with a proper NEC electrical system can cause personal injury, compressor package damage and void compressor package warranty

**NOTICE:** To ensure full compressor tank warranty all tank mounted compressor packages must be mounted on factory approved vibration isolation pads. A compressor should NEVER be installed while still on or in its original packaging. Failure to properly install the compressor system with approved vibration isolation pads will result in the compressor tank warranty being void.

**WARNING:** Compressed Air Systems compressors can operate at pressures from 0-250psi depending on the compressor package design and build specifications. Always verify that the system the compressor is installed into can handle the maximum operational pressure the compressor. NEVER install a compressor in a system that can not handle the compressors maximum operating pressure.

**WARNING:** Compressed air is extremely dangerous when not properly used or installed. Always make sure a trained compressed air professional has looked over the air system prior to use. Improper installation or use of compressed air can cause bodily injury or death. NEVER pressurize an object that was not designed to be pressurized. Pressurizing objects not properly engineered for the maximum operating pressure of the compressor system can cause bodily injury or death.



**Compressed Air Systems, LLC**

2626 Skyway Drive  
Grand Prairie, TX, 75052

**1-800-531-9656**

Fax 972-352-6364

**Simplicity. It's What We Do.**